

OPUS C DC Power Systems

OC2066 and OC1666 floor standing Cabinets

OPUS C 24-6.6
OPUS C 48-9.6
OPUS C 60-9.6
OPUS C 110-9.6
OPUS C 220-9.6
OPUS C 24-13.2
OPUS C 48-19.2
OPUS C 60-19.2
OPUS C 110-19.2
OPUS C 220-19.2



POWER
GENERATION &
DISTRIBUTION



PROCESS
INDUSTRY



DEFENCE &
SECURITY



TELECOM



Product Description

OPUS C DC power systems are robust, free convection cooled, N+1 redundant backup power solutions for critical infrastructure applications such as transmission and distribution substations, process industries and special communications.

OPUS C DC power systems consist of MRC-rectifiers, VIDI+ controllers, Connections for mains and battery and wide variety of load distribution.

Features

- Natural Convection cooling
- Models for 24, 48, 60, 110, 125, 220 VDC
- Max 19.2 kW output power
- IP20/IP21 600x600mm cabinets, height 2m or 1.6m, Option: OC0864 Wall Cabinet H800 x W600 x D400 mm
- N+1 redundancy
- Plus or Minus Grounded or Floating
- Battery connection:
 - 1 string with full current: MCB or MCCB
 - Load Distribution Modules as options:
 - 2-pole or 1-pole MCB, NH000/NH00/NH01, Diazed, Switch fuse, MCCB
 - Options: Battery LVD, Load LVD, extra battery connections, Temperature sensors, Battery block voltage monitoring, IP21, bottom entry cabling



Enedo Finland Oy
Martinkyläntie 43, 01720 Vantaa, Finland
Tel +358 9 478 466
www.enedopower.com

Technical Specifications

General construction		Environment and standards	
Cooling	Natural convection	Operating temperature	-20°C ... +45°C
Protection	IP 20 Option IP21	Humidity max	95% relative humidity, non-condensing
Controller user interface	Display and local control in front door	Altitude max	2000 m above sea level
Cabling	From top, Option bottom entry	Safety	IEC/EN 60950-1
Colour	Cabinet RAL 7037 Door RAL 7024	EMC	Emissions: IEC/EN 61000-6-4 Immunity: IEC/EN 61000-6-2 Harmonic currents IEC/EN 61000-3-2 Voltage fluctuation & flicker: IEC/EN 61000-3-3
Dimensions	Height 2000 or 1600 mm Width 600 mm Depth 600 mm		

Input	OPUS C 24-, OPUS C 48-, OPUS C 60-, OPUS C 110-, OPUS C 220-				
AC-connection	3W + N + PE				
Nominal voltage	230 / 400 VAC				
Range, full	180 – 275 VAC				
Range, reduced	140 – 180 VAC				
Frequency	45 to 65 Hz				
Internal protection	16 A MCB / rectifier module				
Mains terminal	Terminal blocks 10 mm ²				
	OPUS C 24-6.6	OPUS C 48-9.6	OPUS C 60-9.6	OPUS C 110-9.6	OPUS C 220-9.6
Nominal current	10.2 A			15.4 A	
Maximum current	13.8 A			19.4 A	
Inrush current per rectifier	14.7 A			18 A	
Main switch	63 A				
Recommended mains fuse	3 x 25 A				
	OPUS C 24-13.2	OPUS C 48-19.2	OPUS C 60-19.2	OPUS C 110-19.2	OPUS C 220-19.2
Nominal current	2 x 10.2 A			2 x 15.4 A	
Maximum current	2 x 13.8 A			2 x 19.4 A	
Inrush current per rectifier	14.7			18 A	
Main switch	2 x 63 A				
Recommended mains fuse	2 x (3 x 25 A)				

Output	OPUS C 24-6.6	OPUS C 48-9.6	OPUS C 60-9.6	OPUS C 110-9.6	OPUS C 220-9.6
Grounding	+ , - or floating	+ or floating	+ or floating	floating	floating
Nominal voltage	24 VDC	48 VDC	60 VDC	110 VDC	220 VDC
Voltage range	21 -30 VDC	42 – 58 VDC	51 – 72 VDC	97 – 132 VDC	189 – 265 VDC
Ripple noise	< 100 mVp-p	< 100 mVp-p	< 100 mVp-p	< 100 mVp-p	< 100 mVp-p
Rectifiers	Max 6	Max 6	Max 6	Max 6	Max 6
Maximum current	275A @ 24V	197A @ 48V	161A @ 60V	87A @ 110V	43A @ 220V
Power max.	6.6 kW	9.6 kW	9.6 kW	9.6 kW	9.6 kW
Redundant power	5.5 kW	8.0 kW	8.0 kW	8.0 kW	8.0 kW
Output terminals	Loads connected to distribution fuses				



Enedo Finland Oy
 Martinkyläntie 43, 01720 Vantaa, Finland
 Tel +358 9 478 466
 www.enedopower.com

Output	OPUS C 24- 13.2	OPUS C 48- 19.2	OPUS C 60- 19.2	OPUS C 110- 19.2	OPUS C 220- 19.2
Grounding	+ , - , floating	+ , floating	+ , floating	floating	floating
Nominal voltage	24 VDC	48 VDC	60 VDC	110 VDC	220 VDC
Voltage range	21 -31 VDC	42 – 58 VDC	51 – 72 VDC	97 – 132 VDC	189 – 265 VDC
Ripple noise	< 100 mVp-p	< 100 mVp-p	< 100 mVp-p	< 100 mVp-p	< 100 mVp-p
Rectifiers	Max 12	Max 12	Max 12	Max 12	Max 12
Maximum current	550A @ 24V	394A @ 48V	322A @ 60V	174A @ 110V	86.4 A @ 220V
Power max.	13.2 kW	19.2 kW	19.2 kW	19.2 kW	19.2 kW
Redundant power	12.1 kW	17.6 kW	17.6 kW	17.6 kW	17.6 kW
Output terminals	Loads connected to distribution fuses				

Battery connection	OPUS C 24- 6.6 F	OPUS C 48- 9.6 P	OPUS C 60- 9.6 P	OPUS C 110- 9.6 F	OPUS C 220- 9.6 F
Battery breaker in system	2 x MCCB 250A 2-p	3 x MCB 200A 1-p	3 x MCB 200A 1-p	2 x MCB 100A 2-p	2 x MCB 63A 2-p
Optional breakers	Max 4 MCCB				
Battery shelves	2	3	3	2 or 3	3
	OPUS C 24- 13.2 F	OPUS C 48- 19.2 P	OPUS C 60- 19.2 P	OPUS C 110- 19.2 F	OPUS C 220- 19.2 F
Battery breaker in system	2 x MCCB 500A 2-p	2 x MCCB 400A 1-p	2 x MCCB 400A 1-p	2 x MCCB 250A 2-p	2 x MCB 100A 2-p
Optional breakers				Max 4 MCCB	
Battery shelves	Optional				

Load Distribution Panels, configurable



MCB panels



NH00/NH01 fuse panels



Diazed fuse panels



Cylinder fuse panels



Switch fuse panels

Load Distribution Options	OPUS C 24- 6.6	OPUS C 48- 9.6	OPUS C 60- 9.6	OPUS C 110- 9.6	OPUS C 220-9.6
1-pole MCB, 2...63A	Max 48 loads	Max 60 loads	Max 60 loads	N/A	N/A
2-pole MCB, 2...63A	Max 24 loads	Max 24 loads	Max 24 loads	Max 30 loads	Max 25 loads
2-pole MCB, 2...63A + AUX or alarm	Max 20 loads	Max 20 loads	Max 20 loads	Max 24 loads	Max 25 loads
1-pole NH000/00 Fuses	Max 2 x 12 loads	Max 2 x 12 loads	Max 2 x 12 loads	N/A	N/A
2-pole NH000/00 Fuses	Max 2 x 6 loads	Max 2 x 6 loads	Max 2 x 6 loads	Max 2 x 6 loads	Max 2 x 6 loads
1-pole NH01 Fuses	Max 2 x 6 loads	Max 2 x 6 loads	Max 2 x 6 loads	N/A	N/A
2-pole NH01 Fuses	Max 2 x 3 loads	Max 2 x 3 loads	Max 2 x 3 loads	Max 2 x 3 loads	Max 2 x 3 loads
2-pole Diazed Fuses	Max 2 x 8 loads	Max 2 x 8 loads	Max 2 x 8 loads	Max 2 x 8 loads	Max 2 x 8 loads
2-pole cylinder fuses E92/32PV	Max 2 x 12 loads	Max 2 x 12 loads	Max 2 x 12 loads	Max 2 x 12 loads	Max 2 x 12 loads
2-pole switch fuses incl. 2-pole NH00 fuse	Max 2 x 3 loads	Max 2 x 3 loads	Max 2 x 3 loads	Max 2 x 3 loads	Max 2 x 3 loads

Load Distribution Options	OPUS C 24-13.2	OPUS C 48-19.2	OPUS C 60-19.2	OPUS C 110-19.2	OPUS C 220-19.2
1-pole MCB, 2...63A	Max 2 x 24 loads	Max 2 x 24 loads	Max 2 x 24 loads	N/A	N/A
2-pole MCB, 2...63A	Max 2 x 12 loads	Max 2 x 12 loads	Max 2 x 12 loads	Max 2 x 12 loads	Max 2 x 10 loads
2-pole MCB, 2...63A + AUX or alarm	Max 2 x 10 loads	Max 2 x 10 loads	Max 2 x 10 loads	Max 2 x 10 loads	Max 2 x 10 loads
1-pole NH000/00 Fuses	Max 2 x 12 loads	Max 2 x 12 loads	Max 2 x 12 loads	N/A	N/A
2-pole NH000/00 Fuses	Max 2 x 6 loads	Max 2 x 6 loads	Max 2 x 6 loads	Max 2 x 6 loads	Max 2 x 6 loads
1-pole NH01 Fuses	Max 1 x 6 loads	Max 1 x 6 loads	Max 1 x 6 loads	N/A	N/A
2-pole NH01 Fuses	Max 2 x 3 loads	Max 2 x 3 loads	Max 2 x 3 loads	Max 2 x 3 loads	Max 2 x 3 loads
2-pole Diazed Fuses	Max 2 x 8 loads	Max 2 x 8 loads	Max 2 x 8 loads	Max 2 x 8 loads	Max 2 x 8 loads

Other options
IP21 drip water cover
Cable duct for bottom entry cables, assembled side of cabinet
NTC Temperature sensor
Load LVD contactors, Battery LVD contactors
Controllers: VIDI+ or VIDI+ I/O.
Auxiliary controllers: VIDI-BM battery monitoring, VIDI-LVD Low Voltage Disconnect driver

Typical block Diagram

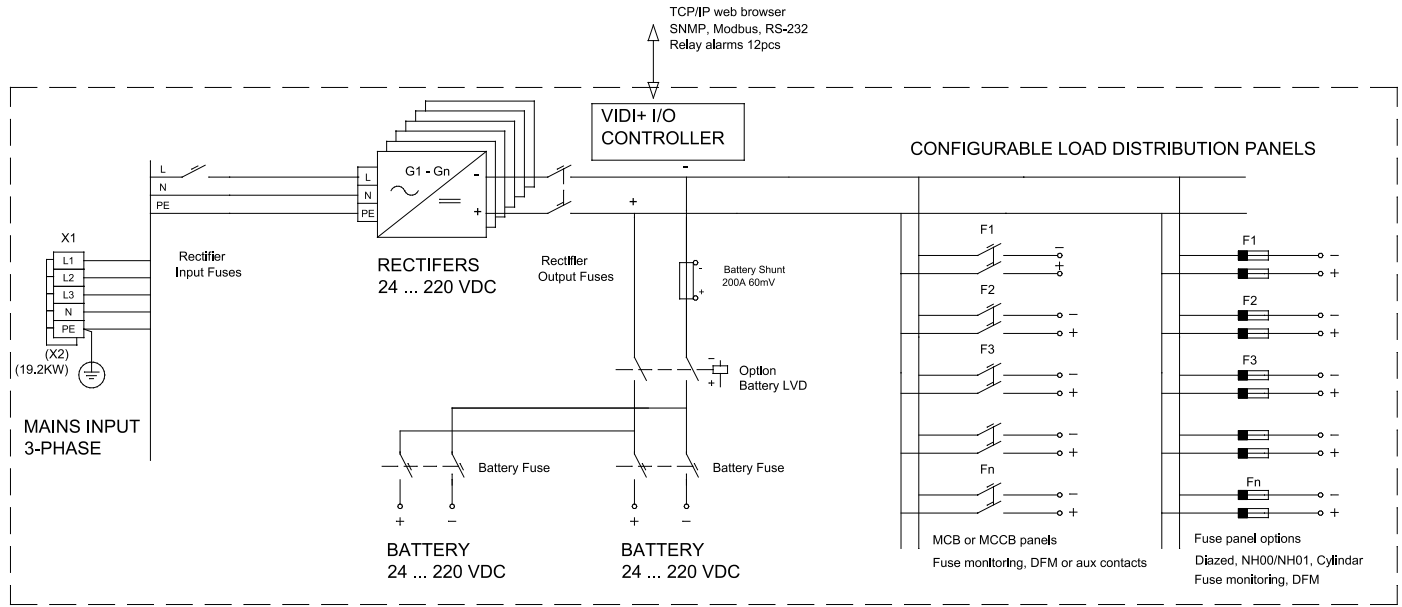

Enedo Finland Oy
 Martinkyläntie 43, 01720 Vantaa, Finland
 Tel +358 9 478 466
 www.enedopower.com



OPUS C 110-9.6 CS2066 F
IP21 2100 x 600 x 600 mm
Diazed load distribution
Switch fuse / NH00 battery fuses

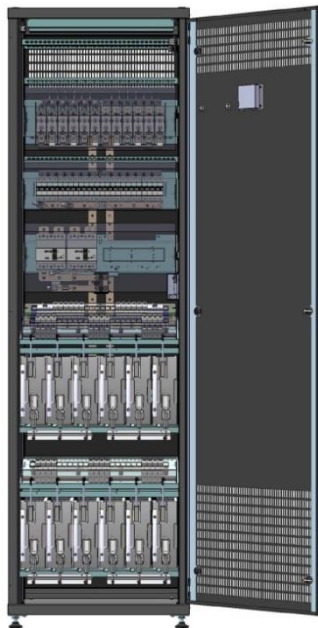

OPUS C 60-19.2 CS2066 P
IP20 2000 x 600 x 600 mm
MCB load distribution
Fuse link NH00/01 load distribution
MCCB battery fuses

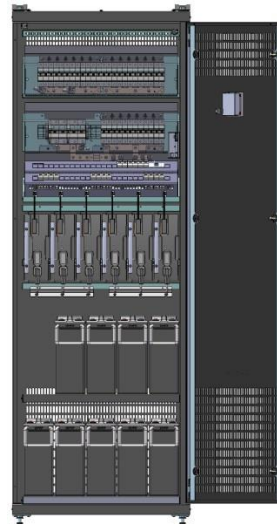

OPUS C 110-9.6 CS1666 F
IP20 1600 x 600 x 600 mm
MCB load distribution
MCB battery fuses



Wall cabinet
OPUS C 24-6.6 OC0864
IP20 800 x 600 x 400 mm
Bulk output
MCB load distribution
Switch fuse battery fuses

Order Information

Name	Order number	Description
OPUS C 24-6.6 CS2066 F	9220X0000195	24VDC, 6.6 kW, Floating
OPUS C 24-13.2 CS2066 F	9220X0002629	24 VDC, 13.2 kW, Floating
OPUS C 24-13.2 CS2066 P	9220X0002631	24 VDC, 13.2 kW, Positive Grounded
OPUS C 48 9,6 CS1666 F	9220X0001804	48V DC, 9.6 kW, Floating
OPUS C 48-9.6 CS2066 F	9220X0002131	48V DC, 9.6 kW, Floating
OPUS C 48-9.6 CS2066 P	9220X0000121	48 VDC, 9.6 kW, Positive Grounded
OPUS C 48-19.2 CS2066 P	9220X0000424	48 VDC, 19.2 kW, Positive Grounded
OPUS C 60-9.6 CS2066 P	9220X0000122	60 VDC, 9.6 kW, Positive Grounded
OPUS C 60-19.2 CS2066 P	9220X0000426	60 VDC, 19.2 kW, Positive Grounded
OPUS C 110-9.6 CS2066 F	9220X0000123	110V DC, 9.6 kW, Floating
OPUS C 110-19.2 CS2066 F	9220X0001565	110 VDC, 19.2 kW, Floating
OPUS C 220-9.6 CS2066 F	9220X0000124	220V DC, 9.6 kW, Floating
OPUS C 220-19.2 CS2066 F	9220X0000887	220 VDC, 19.2 kW, Floating

*) other configurations on request