

INTRODUCTION

This application note provides technical information for the connection and application of the control signals to STRATO LED drivers. STRATO drivers incorporate 2 control signals for connection to LED assemblies that can be used to enhance performance and features of the end product:

Dim: The function of the Dim input is to allow dimming of the LED through a 0-10 V or similar interface. The dimming characteristics have been tailored to meet the requirements of IEC 60929 Annex E.

Temperature Sense: The function of the temperature sense input is to provide a means for thermal protection of the LED assembly by reducing the output current of the driver if the temperature at the remote location exceeds a predetermined level.

The inputs may also be used to trim the output set current to a lower value than the rated current.

ELECTRICAL CONNECTION OF STRATO LED DRIVERS

Figure 1 shows a basic schematic diagram of the STRATO driver and the connections to the LED and signals of the driver.

STRATO LED drivers include a Dimming and temperature sense input as well as the LED output connections and a dedicated dimming return for a total of 5 wires. If the dimming or temperature sense functions will not be used, the wires should be terminated or capped.

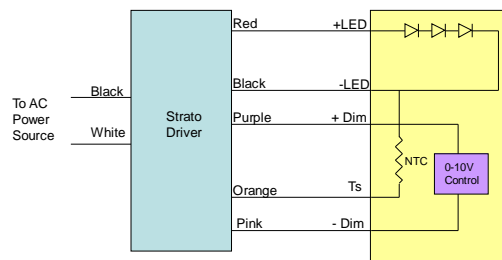


Figure 1

All electrical connections shall be in accordance with state, local and NEC requirements.

- DC output to the LED is provided on the **Red** (+ LED) and **Black** (- LED) leads of the driver.
- The temperature sense is to be connected between the **Orange** (Ts) wire and the **Black** (-) or **Pink** wire.
- Dimming controls are connected between the **Purple** wire (+ Dim) and the **Pink** wire (- Dim).

The dimming and temperature sense inputs are suitable for connection to Class 2 circuits. Then, any device to be connected to the driver must have the appropriate safety approval / recognition as a Class 2 device.



THE -DIM WIRE IS PHYSICALLY CONNECTED TO THE DRIVER -LED WIRE. BE CERTAIN THAT THE DEVICE OR EQUIPMENT BEING CONNECTED TO THE DRIVER DOES NOT IMPOSE A VOLTAGE BETWEEN THESE CONNECTIONS. DAMAGE OF THE FIXTURE OR DRIVER MAY RESULT FROM A MISAPPLICATION OF THESE CONNECTIONS.

DIMMING CHARACTERISTICS

By controlling the voltage at the dimming input between 1 V and 10 V, the output current of the driver will change from 10 % to 100 % of rated current. The Dim inputs can be connected in parallel with other STRATO drivers to enable control of multiple fixtures from a single control point.

The driver includes an internal pull-up; therefore, if no connection is made to the dimming input, the driver will operate at the nominal set point. If the dimming input (+ Dim) is shorted to the –LED wire (black) or the -Dim wire (pink), the output current will be 10 % of the driver rating. The external dimming control is not required to inject a voltage into the driver but must be capable of sinking current provided by the driver at the dimming input connection. If the external dimming control does provide a 0-10 V source, it must also be capable of sinking the current from the dimming input.

Figure 2 is a graph showing the output current versus dimming voltage at the dimming input. The output current is normalized to 100 % of the driver rating.

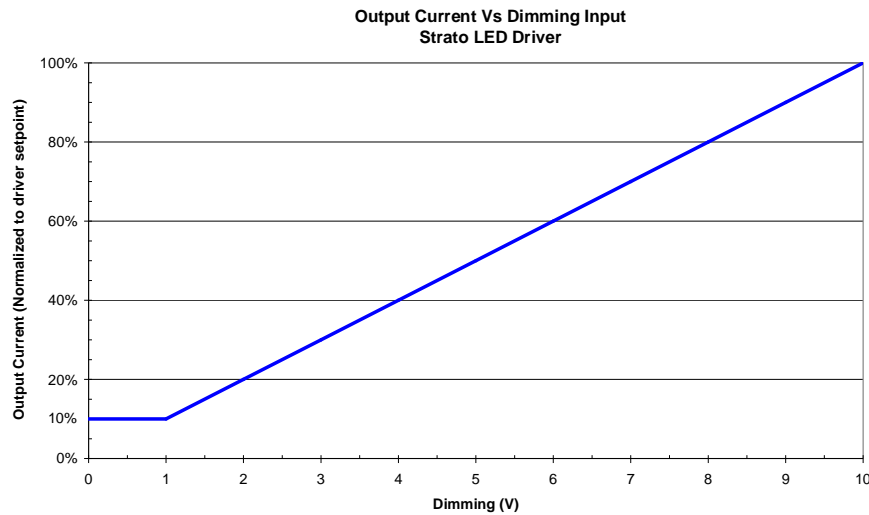


Figure 2

The interface of the dimming control circuitry must be capable of operating over a voltage range of 0 to 15 V and sinking current from the driver at up to 1 mA per driver. The interface can be a simple variable resistor, electronic circuitry that controls the exact voltage to the interface or certain 0-10 V dimmers produced for various other types of lighting.

DIMMING OPTIONS

STRATO drivers will accept various options control options to enable dimming of the output current. The following table summarizes the most common configurations along with the corresponding electrical requirements.

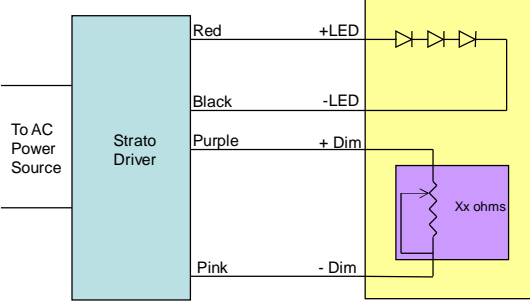
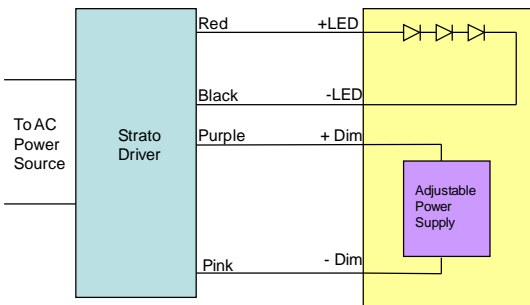
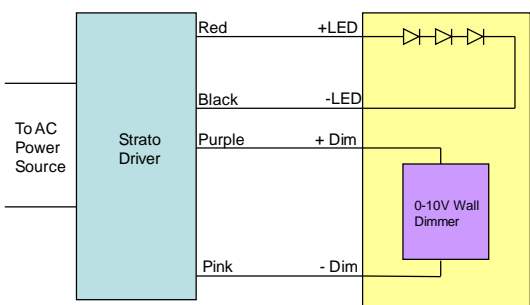
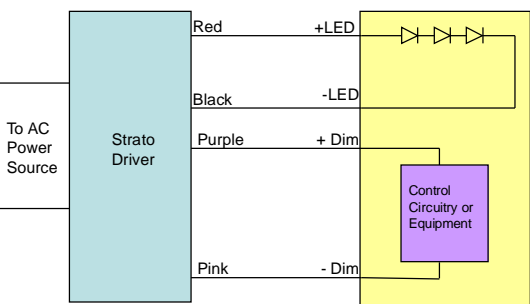
Interface	Circuitry	Requirements / Limitations
<p>Variable Resistor</p>		<p>Resistor range of <1500 ohms to reduce output current to 10 % and >100k ohms to achieve 100% current. Refer to Figure 3 for a graph of output current versus value of the resistor for a single driver.</p>
<p>Adjustable Power Supply</p>		<p>Power supply must be capable of sinking 1 ma from each driver. If multiple drivers are to be connected to a single power supply, it must be capable of sinking 1ma per driver. A series diode is not required to protect the driver. If a series diode is used, it may result in increase the minimum dimming level to >10 %.</p>
<p>0-10 V Wall Dimmer</p>		<p>0-10 V dimmers are not well characterized. Therefore, performance may vary between manufacturers. As additional drivers are added to a single dimmer, the dimming value may change due to the increased current into the dimmer. Example: Lutron Nova - NFTV</p>
<p>Control Circuitry or Equipment</p>		<p>Any circuitry or equipment must be capable of sinking 1 mA from each driver. If multiple drivers are to be connected to a single piece of control equipment, it must be capable of sinking 1 mA per driver.</p>

Figure 3 shows the relationship between the value of the resistor connected across the dimming input versus the output current of a single driver.

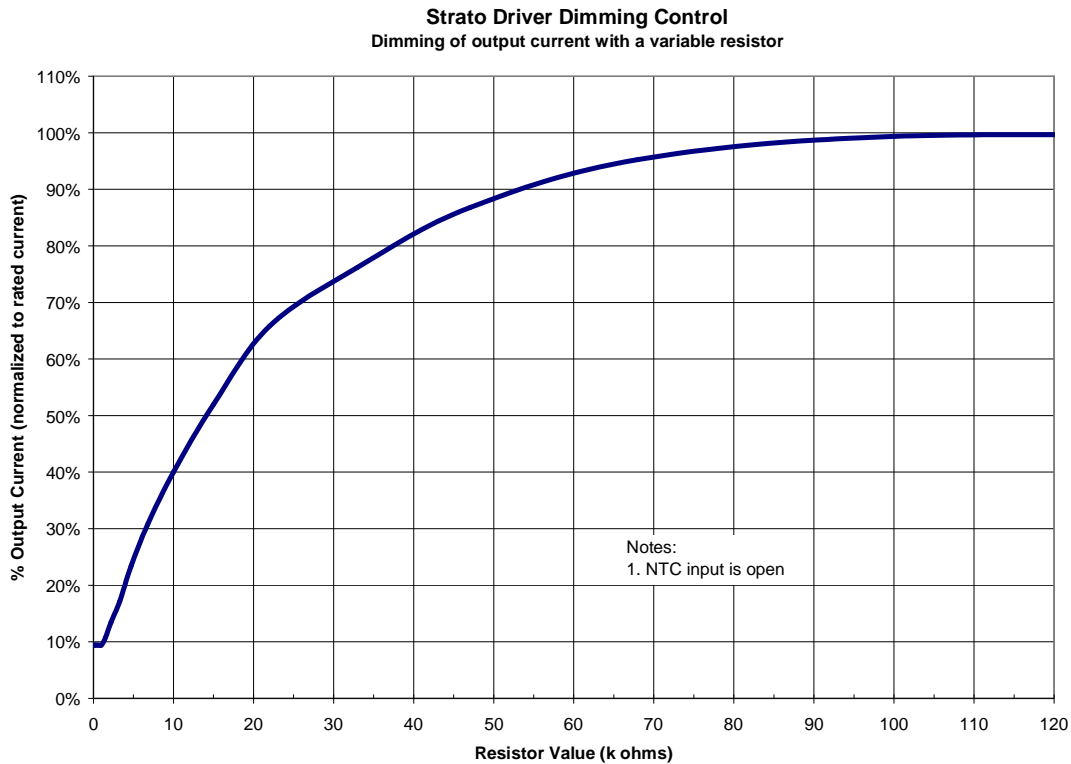


Figure 3

When using a power supply, control equipment/circuitry or similar device, care must be taken to ensure the equipment is isolated from the AC power source. If the dimming connections are to be wired as a Class 2 circuit, all connected equipment must have the appropriate safety approvals for Class 2 circuits.

When connecting multiple drivers to a single control device, it must be appropriately rated and capable of sinking 1mA of current from each connected driver. As the number of drivers increase, the dimming performance characteristics may change due to the increased current into the dimming control circuitry (depending on the characteristics of the external circuit).

The length of the dimming circuit wiring, wire size and the number of drivers connected to the dimming control must be designed so that the total voltage drop is less than 0.3V between the drivers and the dimming control.

TRIMMING THE NOMINAL OUTPUT CURRENT WITH THE DIM INPUT

The dimming input of STRATO can also be used to trim the output current set point. As shown in **Figure 4**, a fixed resistor can be connected between the + Dim and – Dim inputs to reduce the output current set point.

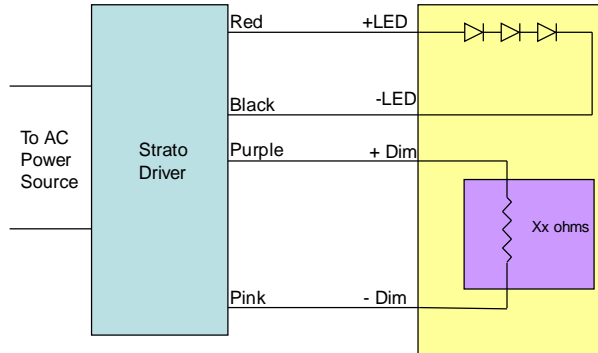


Figure 4

The selection of the trim resistor can be determined from the graph in Figure 3. This graph pertains to a resistor for a single driver. For systems utilizing multiple drivers with a single dimming function, the resistor value from Figure 3 can be applied to each driver or a single resistor equal to the value in Figure 3 divided by the number of drivers can be used.

Trimming of the output current via the dimming input should be limited to a reduction of 20 % (80-100 % of rated current). While it is possible to trim the current to as low as 10 % of rated current, some specifications of the driver will not be met, however the driver will not be damaged.

TRIMMING AND DIMMING WITH THE DIM INPUT

It is possible to utilize the dimming input to both trim and dim the output current. A fixed resistor can be connected between the + Dim and –Dim inputs as shown in the previous section to trim the output current set point. Then the dimming control can be added to the dimming input, in parallel with the fixed resistor. **Figure 5** is a schematic of the configuration utilizing a fixed resistor to set the current and a 0-10V wall dimmer to provide dimming control.

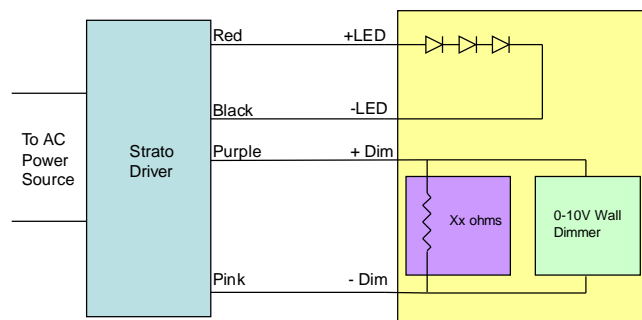


Figure 5

In addition to the above example with a wall dimmer, it is possible to utilize all of the interfaces outlined in the Dimming Options section. However, care must be exercised when using a dimming method that applies a voltage to the driver. This is the case with a power supply or control circuitry/equipment. In these cases, the dimming device may be capable of raising the dimming input voltage above the reduced voltage from the fixed resistor resulting in the output current exceeding the trimmed value. A series isolation diode can be used to prevent this from occurring but this may limit the low end of the dimming range and not be capable of achieving 10 % dimming. **Figure 6** shows the location and polarity of the series diode.

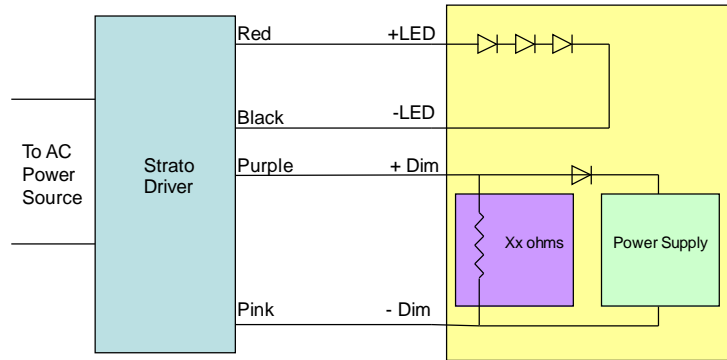


Figure 6

It is still possible to connect the dimming inputs of multiple drivers to a single dimming circuit by simply connecting the +Dim and -Dim inputs in parallel. The trim resistor could be attached to each driver individually (with the value per Figure 3) or a single resistor (with a value per Figure 3 divided by the number of drivers). Refer to **Figure 7** for a simplified schematic showing the location of the trim resistor.

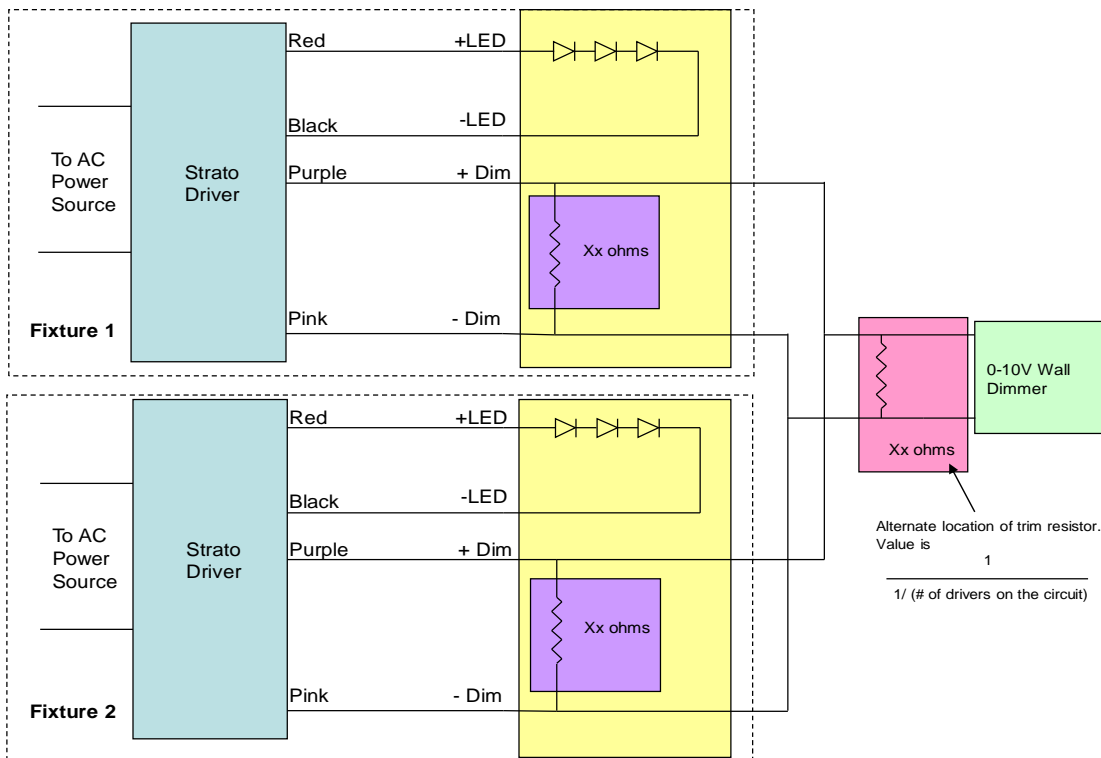


Figure 7

With this configuration of multiple drivers, if a driver fails, the output current of the remaining drivers may be reduced. Refer to Temperature sense – Trimming of the Output Current for an alternate approach that does not have this effect.

There is a limitation to the dimming range when used in combination with trimming the output current via the dimming input. Since the output set point is trimmed from the rating of the driver by the fixed resistor, the driver will dim over a range of 10 % of rated current to the new set point determined by the external resistor. There will be dead travel in the dimmer control from the point at which the new set point current is achieved to the maximum value.

Figure 8 shows a graph of the dimming characteristics when the set point has been reduced to 80% of the rated current. As the dimming input voltage is increased, at 8 V (80 %), maximum output current is achieved and further increase in the dimming input voltage will have no effect on the output current.

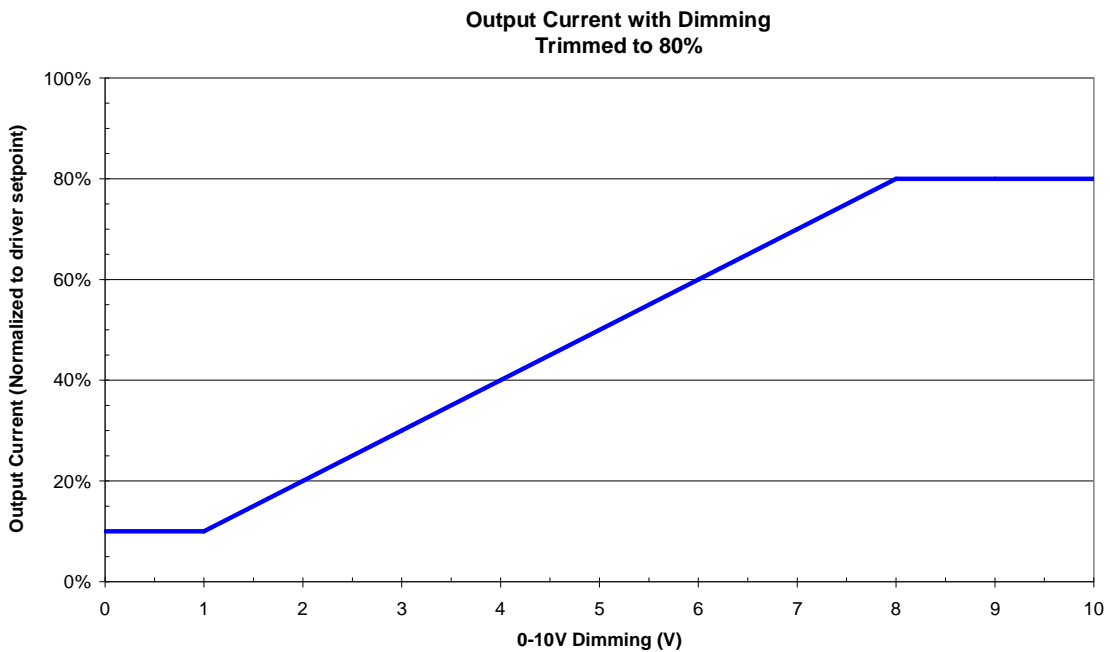


Figure 8

TEMPERATURE SENSE

The external temperature sense input is used to connect to an external NTC resistor, thermostat or circuit located near the LED to limit the maximum temperature of the LED assembly.

The driver includes an internal pull-up; therefore, if no connection is made to the temperature sense input, the driver will operate at the nominal set point. If the temperature sense input is shorted to the –LED wire (black) or the –Dim wire (pink), the output current will be reduced to approximately 20 % of the driver rating.

TEMPERATURE SENSE - CHARACTERISTICS

By applying a variable resistance at the temperature sense input, the output current of the driver can be limited to help protect the LED against over temperature conditions.

The following graph (**Figure 9**) shows the relationship between the resistance connected to the temperature sense input and the corresponding reduction in the output current of the driver.

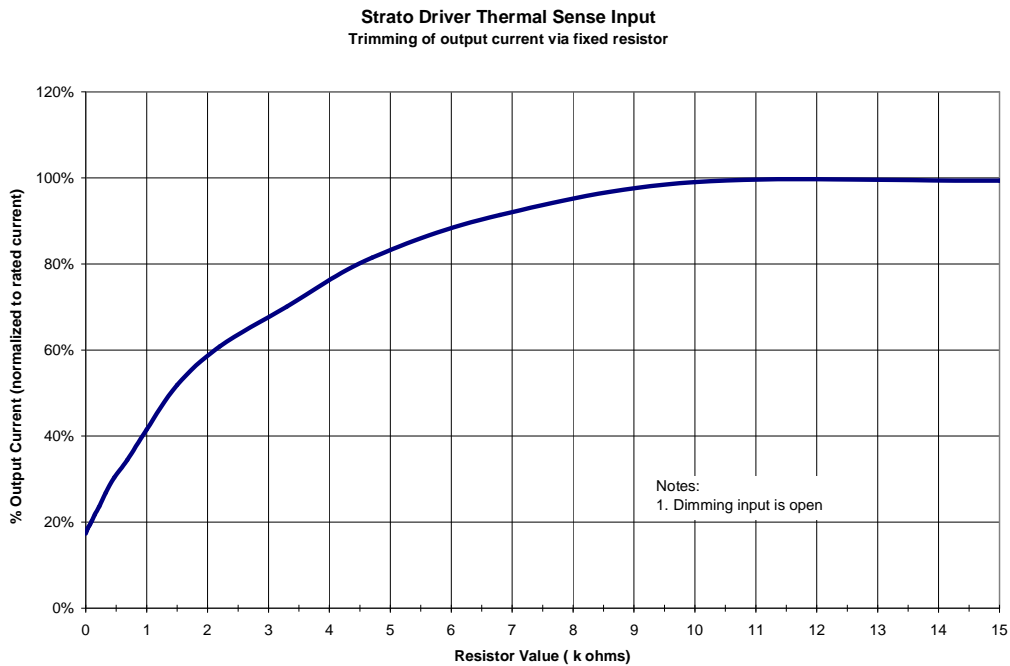


Figure 9

TEMPERATURE SENSE - OPTIONS

There are numerous options for connecting external controls to the STRATO driver and provide a level of protection to the LED. The following summarizes the most common methods and the associated circuitry and characteristics.

A. NTC Resistor

Figure 10 shows the connection of a simple NTC resistor connected to the temperature sense input of the STRATO driver. For best performance, the NTC resistor should be located close to the LED. With this configuration, a degree of over temperature protection of the LED is possible.

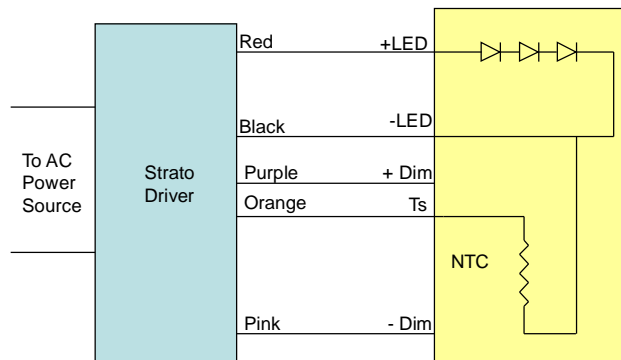


Figure 10

STRATO has been designed to operate with a 100k NTC resistor to provide a knee in the output current regulation at approximately 80 °C to 85 °C. The graph in **Figure 11** shows the reduction in output current as the temperature of the NTC rises above 80 °C. For this example, the NTC is an SMD 100k device from Vishay, part number NTCS0805E3104JXT. Alternatively, Vishay offers a similar NTC resistor (Vishay PN NTCALUG02A104H) that is in a ring lug for use in non-SMD applications.

At temperatures less than 80 °C, the temperature sense input has no effect on the drivers output current. As the temperature rises above 80 °C, the output current of the driver begins to drop resulting in a reduction in the temperature at the LED. Many factors, predominately the thermal impedance of the LED heatsink, play a role in determining the ultimate thermal equalization.

If different knees are required, the value or characteristic of the NTC can be changed. The graph of Figure 8 can be used to determine the required resistance characteristics of alternate NTC resistors.

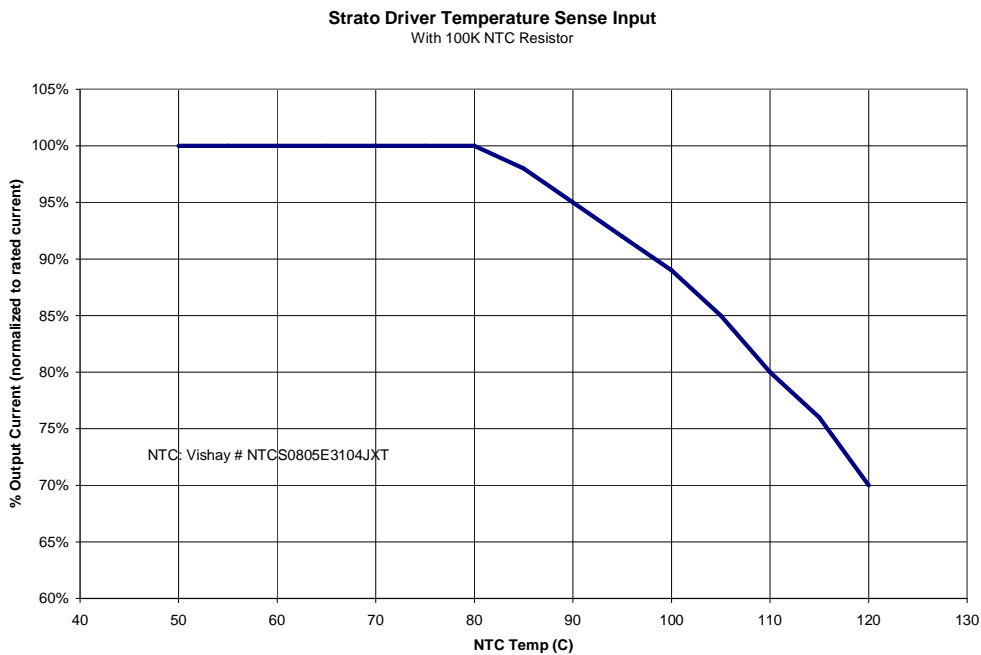


Figure 11

B. Thermostat

Figure 12 shows a simple N.O. (normally open) thermostat connected to the temperature sense input. In this configuration, the driver will reduce the output current to approximately 20% of the rated output current when the thermostat closes. The output current will be regulated at this level while the thermostat is closed. When the thermostat opens (due to the reduction in heat generated), the driver will revert to the full rated current.

Due to the low level (<15V and <5mA) signal characteristics of the temperature sense input, make certain an appropriately rated thermostat is chosen.

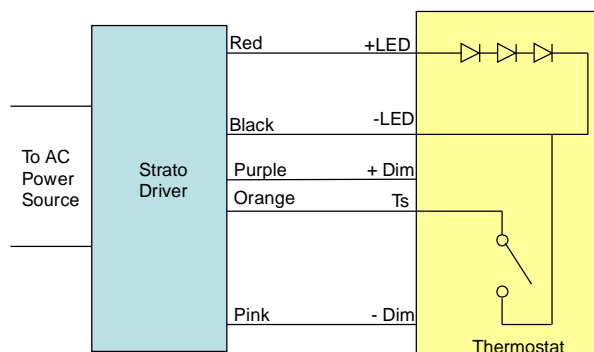


Figure 12

C. PTC resistor

Unfortunately, thermostats are fairly expensive devices and there are very limited sources for SMT devices. By utilizing simple circuitry and a PTC limiting temperature sensor, the over temperature characteristics can be defined in the end product. The PTC device starts out as a relatively low resistance at low temperatures. As the temperature increases, the PTC has a very sharp knee that can be used to trigger various circuits. The possibilities are almost limitless from a simple thermostat action to a pre-determined sequence of the output current to indicate a thermal shutdown. This may be beneficial to differentiate an over temperature condition from a faulty fixture.

Figure 13 shows a simple schematic diagram of a circuit that would act in a similar fashion as a thermostat.

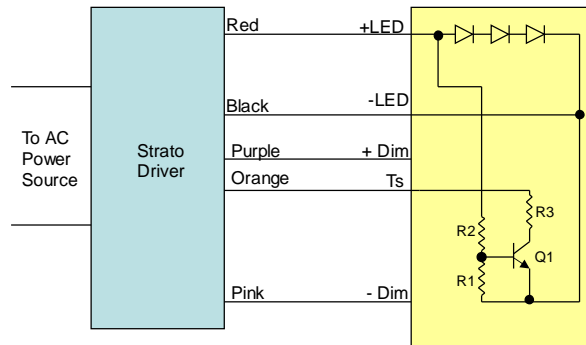


Figure 13

R1 is the PTC limiting temperature sensor such as an EPCOS B59601A0085A062 (85 °C). R2 is a fairly high impedance resistor (>100k typically) selected to provide sufficient current to the base of the transistor. Transistor Q1 is a general purpose NPN transistor. The value of R3 is selected to set the output current when in an over-temperature condition. For a minimum value of 20 % of the rated current, the resistor can be any value <100 ohms. If a setting greater than 20% is desired, the value can be determined from Figure 8.

When the sensed temperature is less than the rating of the PTC, the resistance of the PTC is low keeping Q1 turned off and there is no effect on the STRATO driver. As the sensed temperature reaches the trip point of the PTC, the resistance sharply rises which results in Q1 turning on. This pulls down on the thermal sense pin of the STRATO driver and reduces the output current. The thermal sense pin will source a maximum current of 4 mA.

Due to the temperature sense input being relatively high impedance, the resistor (R2) in series with the PTC cannot be connected to the thermal sense input. The connection (R2) to the output of the driver will result in a very minor reduction in the LED current. For instance, in the above example, the drive current to the PTC circuitry is only 0.5 mA.

By adding additional circuitry such as a timer, the on-off characteristics of the over temperature can be customized without effect on the driver.

TEMPERATURE SENSE – TRIMMING OF THE OUTPUT CURRENT

The temperature sense input can also be used to trim the output current by using a resistor, similar to the method described to trim the output via the dim input.

Figure 14 is a graph of the output current reduction based on the value of a fixed resistor attached to the temperature sense input. The current can be trimmed down to 20 % of the rated current.

Trimming of the output current via the temperature sense input should be limited to a reduction of 20 % (80-100 % of rated current). While it is possible to trim the current to as low as 20 % of rated current, some specifications of the driver will not be met, however the driver will not be damaged.

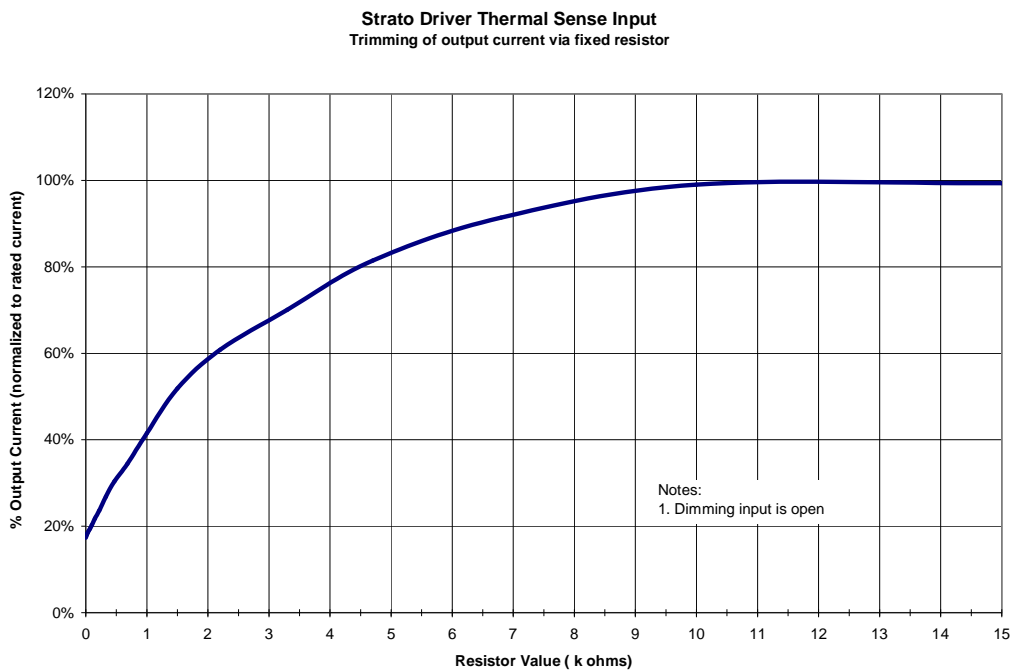


Figure 14

Specifications appearing in ENEDO's catalogues and brochures as well as any oral statements are not binding. All descriptions, drawings and other particulars (including dimensions, materials and performance data) given by ENEDO are as accurate as possible but, being given for general information, and are not binding on ENEDO. ENEDO makes thus no representation or warranty as to the accuracy of such material. We assume no liability other than as agreed in the terms of the individual contracts and we reserve the right to make technical modifications in the course of our product development. Our product information solely describes our goods and services and is in no way to be construed or interpreted as a quality or condition guarantee. The aforesaid shall not relieve the customer of its obligation to verify the suitability of our Products for the use or application intended by the purchaser. Customers are responsible for their products and applications. ENEDO assumes no liability from the use of its products outside of specifications. No license is granted to any intellectual property rights by this document.