

OPUS HE Power Systems

Configurable Wall Cabinet 4.5kW – 12kW

Wall and floor standing installation
OC0864 cabinet 800x600x400mm
Option Rittal wall cabinet

Power Core alternatives 4.5/6kW

OPUS HE 24-4.5 PC64 F
OPUS HE 48/60-6.0 PC64 F
OPUS HE 110/125-6.0 PC64 F
OPUS HE 220-6.0 PC64 F

Power Core alternatives 9/12kW

OPUS HE 24-9.0 PC64 F
OPUS HE 48/60-12.0 PC64 F
OPUS HE 110/125-12.0 PC64 F
OPUS HE 220-12.0 PC64 F

6kW cabinets with Inverters and DC/DC Converters

1-3 x MHE Rectifiers 24-220VDC
1-3 x Inverters / bypass
1-3 x DC/DC Converters
Max 3 slots for INV + DC/DC



Product Description

OPUS HE Power Systems are robust, free convection cooled, N+1 redundant backup power solutions for critical infrastructure applications such as transmission and distribution substations, process industries, railway signalling and telecommunications.

OPUS HE DC power systems consist of MHE rectifiers, VID12 controllers, terminals for mains and battery and load distribution MCBs. System is configurable to meet requirements of the application. On top of 12 configurable relay alarms, system can be remotely monitored via modern communication protocols such as Ethernet TCP/IP, Modbus TCP/IP, SCADA IEC61850, SNMP and RS-232.

OC0864 800x600x400mm standard cabinet systems deliver maximum 12 kW output power at 48, 60, 110, 125 and 220 VDC and 9 kW at 24 VDC output. Cabinets have standard configurations for 3 or 6 rectifier modules and DC/AC inverters or DC/DC converters can be added to the system. Quantity of rectifiers, battery fuses, load distribution and many other features are configurable to match with requirements of the application.

Features

- Efficiency up to 97%
- Convection cooling – no fans
- Outputs 24, 48, 60, 110, 125, 220 VDC
- Flexible design with full front cabling
- VID12 controller, local and remote interfaces
12 x relays, Ethernet, Modbus, IEC61850, SNMP, RS-232
- Configurable load distribution, blocking diode and dropping diode options
- Configurable battery fuses and discharging test
- Battery midpoint monitoring, battery state of health monitoring
- Options: A+B parallel supply, IP21 roof, BLVD contactor, battery block voltage monitoring, inverters & DC/DC converters
- Safety:
Cabinet: EN61439-1, EN61439-2
Rectifiers: EN 62368-1, EN 50124-1 rail
- EMC:
EN 61000-6-1 / -2 / -3 / -4 / -5
EN 50121-4/5 rail, ETSI EN 300386 (48/60V)

Technical Specifications

General construction	
Cooling	Natural convection
Protection	IP 20, Option IP21
Controller user interface	Display and local control in front door & web interface
Cabling	Top cable entry and Bottom cable entry
Colour	Frame RAL 7037, door RAL 7024
Dimensions & weight	Hght 800mm (w/o feet & IP21 roof) Width 600 mm Depth: 400 mm, rectifiers, DC/DC converters only 490mm if inverters included

Environment and standards	
Temp. range	-25 ... +60°C, see derating page 4, Start-up at -40°C
Humidity max	95% relative humidity, non-condensing
Altitude	Max 3km, full power up to 2km above sea level Derating 2% per 100 m between 2-3km
Safety	Cabinet: EN61439-1, EN61439-2 Rectifiers: EN 62368-1, EN 50124-1 rail
EMC	EN61000-6-1 / -2 / -3 / -4 Generic EN61000-6-5 Utility EN 50121-4 Rail, ETSI EN 300 386 (48/60V)

AC Input	
AC connection	TN-S system, 3W + N + PE, (3-phases, neutral and protective earth wires)
Nominal input	220-240 VAC / 3 x 380-415 VAC TN-S system (options: 1- or 2-phase 100-250VAC, 3-phase 208-240VAC)
Input range	Max range: 85 – 300 VAC / 3 x 147–528 VAC Rated full power range: 180 – 275 VAC / 3 x 312–476 VAC (TN-S system) See derating curves below, 1200W per rectifier at 120VAC Temporary high voltage range 275 - 300VAC / 3 x 476 - 528VAC, continuous supply not recommended
Input frequency	Rated 45 - 66 Hz, reduced power at 35 - 45 Hz. Shut down at 35 Hz
Main Switch	63A, 4-pole (L1-L2-L3-N)
Rectifier input protection	MCB C16A / rectifier module
	24V 4.5kW 48V 6kW 60V 6kW 110V 6kW 125V 6kW 220V 6kW
Nominal current	8A @ 220/380V 11A @ 220/380VAC
Maximum phase current	12,5A @ 85-130V 12,5A @ 85-180VAC
Recommended mains fuse	3 x 25 A (TN-S)
	24V 9kW 48V 12kW 60V 12kW 110V 12kW 125V 12kW 220V 12kW
Nominal current	16A @ 220/380V 22A @ 220/380VAC
Maximum phase current	25A @ 85-130V 25A @ 85-180VAC
Recommended mains fuse	3 x 25 A (TN-S)

DC Output	24V	48V	60V	110V	125V	220V
Grounding	2-pole, floating					
Nominal voltage	24 VDC	48 VDC	60 VDC	108 VDC	120 VDC	216 VDC
Voltage factory setting, 2.27vpcc	27.24 VDC	54.48 VDC	68.10 VDC	122.58 VDC	136.20 VDC	245.16 VDC
Voltage range	21-33 VDC	42-59 VDC	51-72 VDC	90-150 VDC	100-160 VDC	178-280 VDC
Static voltage regulation	± 2 % @ load terminals (load, line, temp)			± 1 % @ load terminals (load, line, temp)		
Rectifier module output protection	MCB C63A	MCB C50A	MCB C50A	MCB C20A	MCB C20A	MCB C10A
	24V 4.5kW	48V 6kW	60V 6kW	110V 6kW	125V 6kW	220V 6kW
Quantity of rectifiers	Max 3 pcs					
Max current	187.5A @ 24V	125A @ 48V	100A @ 60V	55.5A @ 108V	50A @ 120V	27.8A @ 216V
Max Power	4.5kW	6kW	6kW	6kW	6kW	6kW
	24V 9kW	48V 12kW	60V 12kW	110V 12kW	125V 12kW	220V 12kW
Quantity of rectifiers	Max 6 pcs					
Max current	375A @ 24V	250A @ 48V	200A @ 60V	111A @ 108V	100A @ 120V	55.5A @ 216V
Max Power	9kW	12kW	12kW	12kW	12kW	12kW

Connection terminals	24V	48V	60V	110V	125V	220V
Mains terminal	X1 Mains input screw terminal blocks 10 mm ² , L1-L2-L3-N-PE					
DC Bulk Output XL1, included to BOM	Screw terminal 95mm ²	Screw terminal 95mm ²	Screw terminal 95mm ²	Screw terminal 50mm ²	Screw terminal 50mm ²	Screw terminal 50mm ²
DC load distribution	Configurable load distribution: 2-pole MCB +aux, connection to protection device directly					
Battery XB1-XB3, batt. qty configurable	Screw terminal 95mm ²	Screw terminal 95mm ²	Screw terminal 95mm ²	Screw terminal 50mm ²	Screw terminal 50mm ²	Screw terminal 50mm ²
Alarms & Inputs	Configurable relay alarms 4 pcs (option up to 12), Spring terminals 0.75mm ² ... 1.5mm ² cable Configurable alarm/temp. inputs 4 pcs (option up to 12), Spring terminals 0.75mm ² ... 1.5mm ² cable					

Battery and Load Connectios

Type A

Battery MCBs in air flow plate, max 125A, 2-pole, 1-3pcs

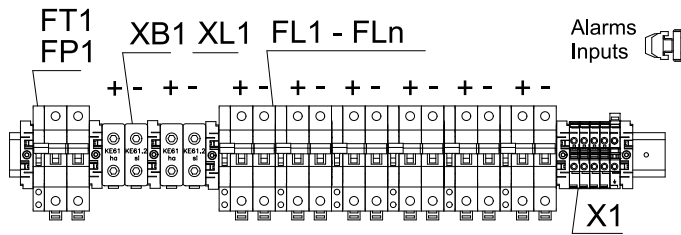
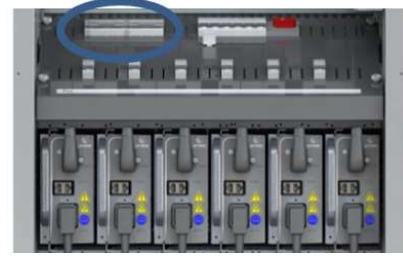

Type B

Battery Switch fuses, NH00 / NH01, max 250A, 2-pole, 1 pc

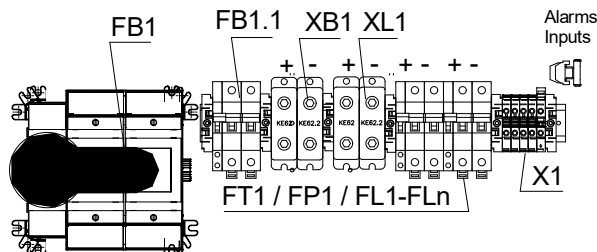
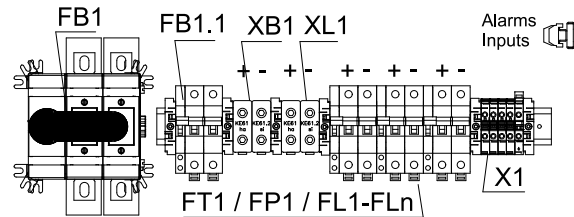

6kW (4.5kW) cabinets	24V 4.5kW	48V 6kW	60V 6kW	110V 6kW	125V 6kW	220V 6kW
MCB battery fuse Type A	MCB D125A 2-pole, 1-3pcs	MCB D125A 2-pole, 1-3pcs	MCB D125A 2-pole, 1-3pcs	MCB D63A 2-pole, 1-3pcs	MCB D63A 2-pole, 1-3pcs	MCB D63A 2-pole, 1-3pcs
Switch fuse battery fuse Type B	NH00 125A 2-pole, 1pc	NH00 125A 2-pole, 1pc	NH00 125A 2-pole, 1pc	NH00 63A 2-pole, 1pc	NH00 63A 2-pole, 1pc	NH00 63A 2-pole, 1pc

12kW (9kW) cabinets	24V 9kW	48V 12kW	60V 12kW	110V 12kW	125V 12kW	220V 12kW
MCB battery fuse Type A	MCB D250A 2-pole, 1pc	MCB D250A 2-pole, 1pc	MCB D250A 2-pole, 1pc	MCB D125A 2-pole, 1-3pcs	MCB D125A 2-pole, 1-3pcs	MCB D63A 2-pole, 1-3pcs
Switch fuse battery fuse Type B	NH01 250A 2-pole, 1pc	NH01 250A 2-pole, 1pc	NH01 250A 2-pole, 1pc	NH00 125A 2-pole, 1pc	NH00 125A 2-pole, 1pc	NH00 63A 2-pole, 1pc

Battery test option	MCB for external discharging test load
A+B parallel supply option	MCB + aux contact for System A + B parallel connection

DC output module	Configuration	Description
Bulk Output terminal, XL1	Included to cabinet BOM	Screw terminal 50-95mm ² 2-p, top of cabinet (wired)
Load MCB + aux, 2-pole, 2A – 63A	Select n x MCB code	Max 6cs of Load Distribution MCBs + aux contacts Max quantity depends on configurations and selected options Schneider C60H-DC series
Load MCB + aux, 1-pole, 2A – 63A	Option	Max 10cs of Load Distribution MCBs + aux contacts Max quantity depends on configurations and selected options 24V-60V models, Schneider iC60N series
Series diode (Blocking diode) module	Option	Semikron 160A, SKKD 162/16, heatsink P3/180
Dropping diode, voltage control module	Option	Semikron 80A or 160A diodes + heatsink

Mechanical Dimensions

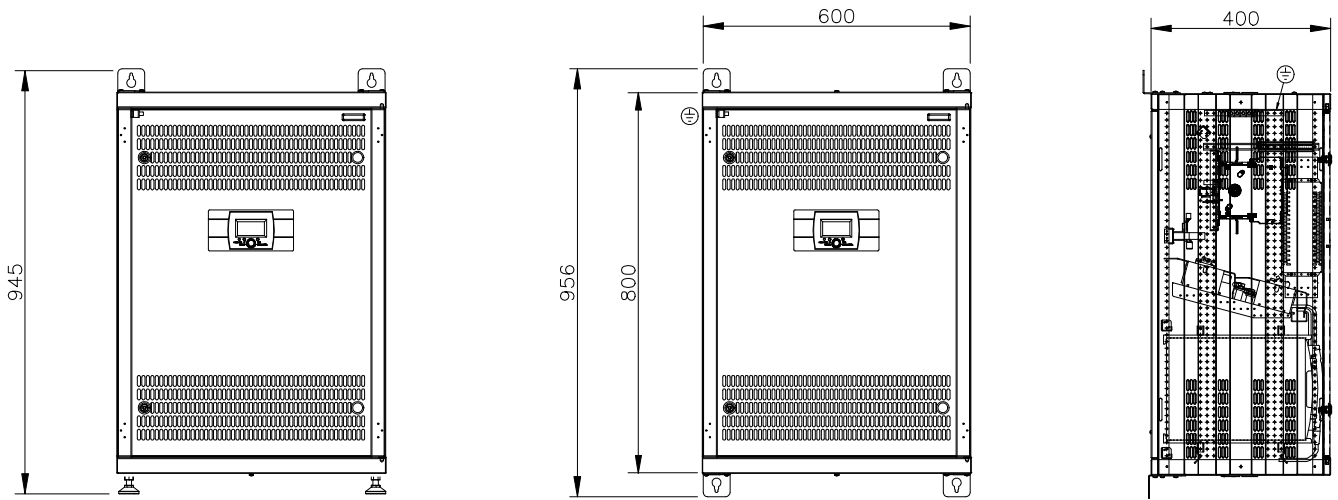

Derating curves

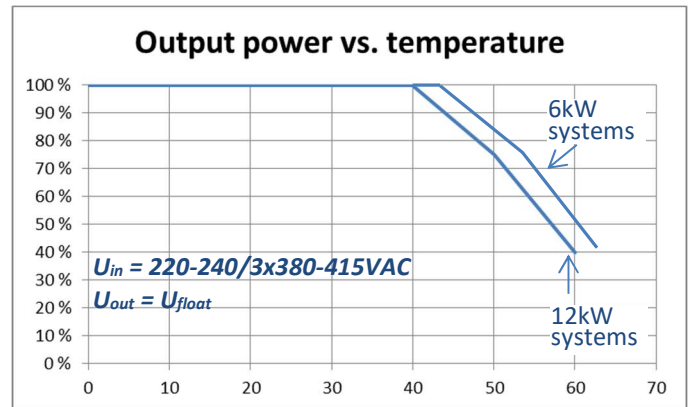
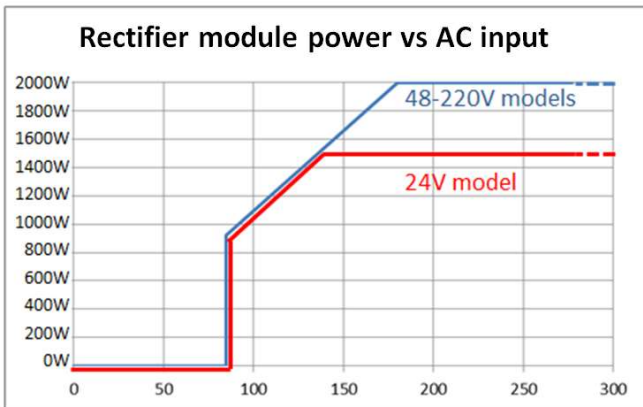

*) Derating curves are continuous power
Short time (<1h) 100% power up to +50°C

Block Diagram, Configurable Wall Cabinet options

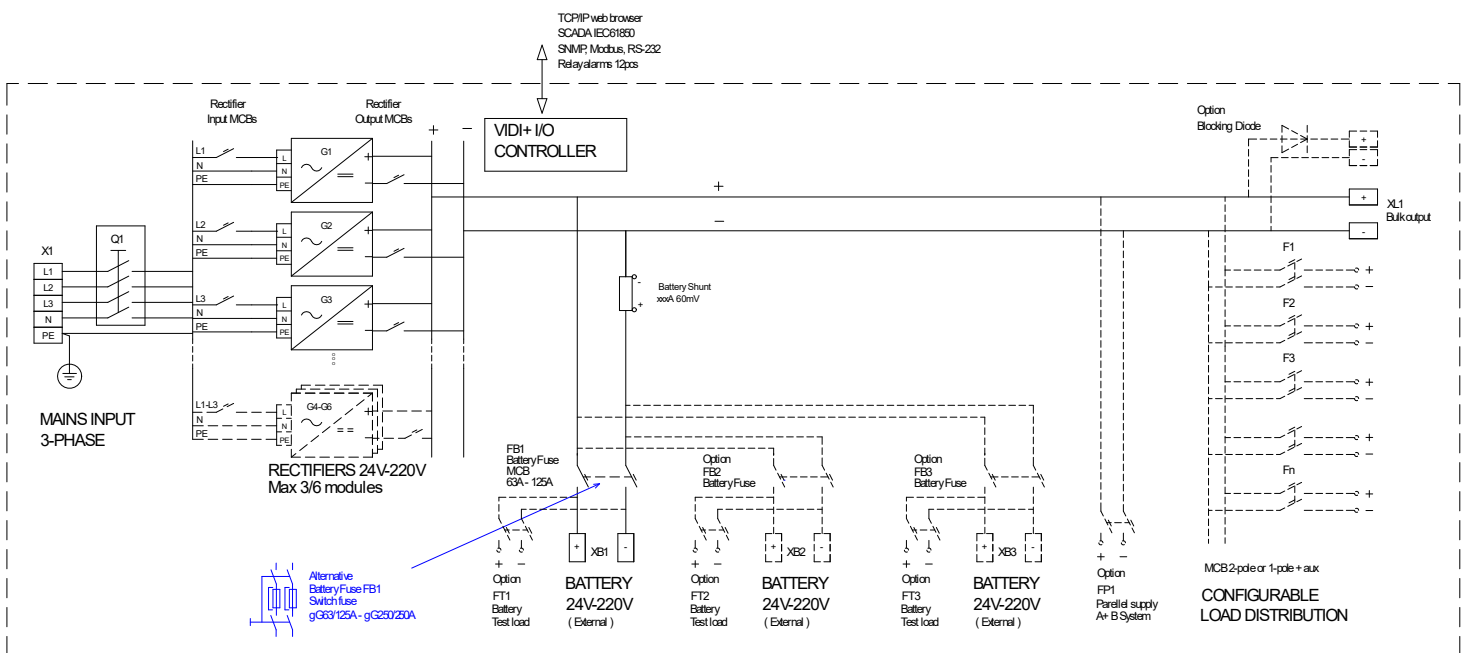

Application example, Multi Voltage Systems including Inverters and DC/DC Converters



MODULAR MULTIVOLTAGE SYSTEM

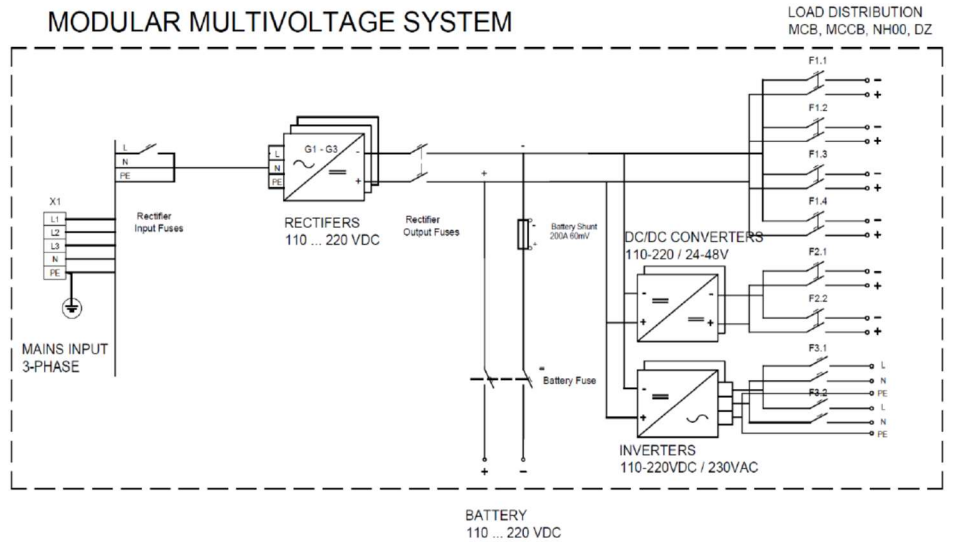

Application example, A+B system, inverter and bypass options

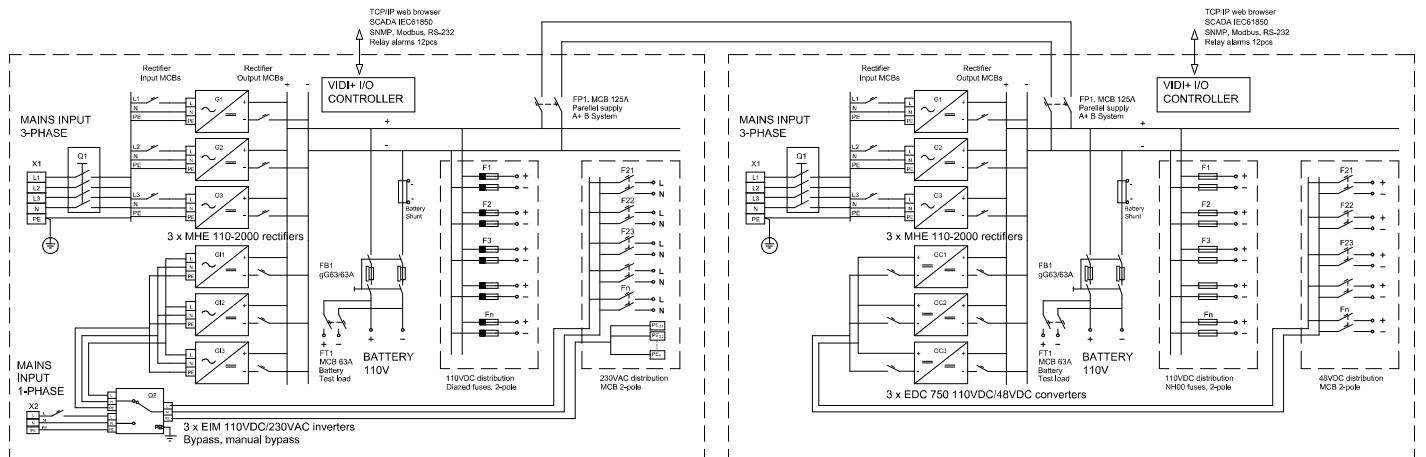

Application example: Modernization of switching center panels, A + B double systems

OPUS OC0864 Wall mountable modular charger, double system

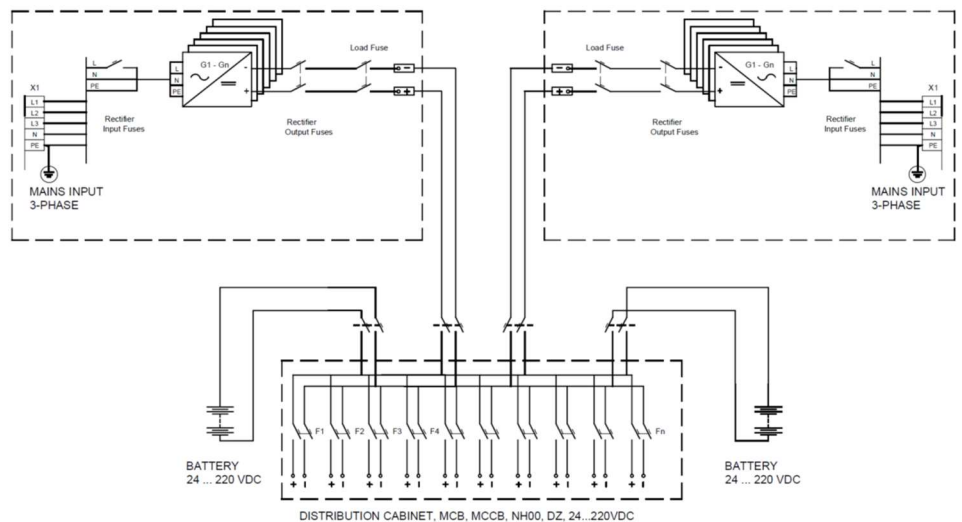
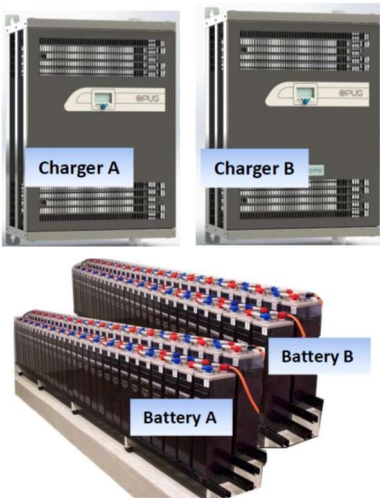

Order Information

Power Core alternatives Power & voltage variants	Order Number	Voltage / Current	Voltage / Current	Qty of MHE rectifiers
OPUS HE 24-4.5 PC64 F	922XW15854	24VDC / 62.5A – 187.5A		1–3 x MHE 24-1500
OPUS HE 24-9.0 PC64 F	922XW15855	24VDC / 62.5A – 375A		1–6 x MHE 24-1500
OPUS HE 48/60-6.0 PC64 F	922XW15856	48VDC / 41.7A – 125A	60VDC / 33.3A – 100A	1–3 x MHE 48-2000 / MHE 60-2000
OPUS HE 48/60-12.0 PC64 F	922XW15857	48VDC / 41.7A – 250A	60VDC / 33.3A – 200A	1–6 x MHE 48-2000 / MHE 60-2000
OPUS HE 110/125-6.0 PC64 F	922XW15860	110VDC / 18.5A – 55.5A	125VDC / 16.7A – 50A	1–3 x MHE 110-2000 / MHE 125-2000
OPUS HE 110/125-12.0 PC64 F	922XW15861	110VDC / 18.5A – 111A	125VDC / 16.7A – 100A	1–6 x MHE 110-2000 / MHE 125-2000
OPUS HE 220-6.0 PC64 F	922XW15864	220VDC / 9.3A – 27.8A		1–3 x MHE 220-2000
OPUS HE 220-12.0 PC64 F	922XW15865	220VDC / 9.3A – 55.5A		1–6 x MHE 220-2000

Cabinet Frame alternatives	Order Number	Dimensions
OC0864 OPUS Wall Cabinet frame, IP20-IP21	8320X0003062	H 800mm x W 600mm x D 400mm, + feet + roof option
Option: RC0864 Rittal VX25 Cabinet, IP20-IP41		H 800mm x W 600mm x D 400mm, + feet + roof option
Option: Custom OPUS OC or IC cabinets, depth 400mm		H xxxx mm x W 600mm x D 400mm

Cabinet Door alternatives	Order Number	Dimensions
OC0864 Cabinet door, standard UIF	D02830	H 800mm x W 600mm

Cabinet roof / IP class alternatives	Order Number	Dimensions
IP21 roof OPUS OC0864, 600x435mm, height +90mm	832X015903	W 600 x D 435 mm, height +90mm

AC supply side configuration

Over voltage protection, 3-phase/2-phase/1-phase supply, Input transformers, A+B 2nd mains input
See price list and configurators

DC circuit configuration

A+B parallel supply, Load LVD, Blocking diodes, Dropping diodes, Rectifier 1-pole/2-pole protection & aux
See price list and configurators

Battery supply configuration

Battery fuses MCB or switch fuse, Battery testing KIT, Battery LVD, Battery midpoint monitoring, Battery block voltage monitoring, Battery temp. monitoring
See price list and configurators

Load distribution

Bulk output terminal included to cabinets, Load distribution up to 6 x MCB 2-p + aux
See price list and configurators

Control and monitoring

VIDI2 system controller, VIDI2-EFD, VIDI aux controllers, I/O extension KITS
See price list and configurators

Power modules

MHE Rectifiers 24VDC – 220VDC, DAC60000 inverters 24VDC-220VDC / 230VAC, DC/DC converters
See price list and configurators

General options

Wire marking, component marking, packing alternatives
See price list and configurators